

Automated System Based on Android Cell Phone for Modernization of Irrigation

Swapnil Thakare

Guided By: Asst. Prof. N.L Aravinda & Prof. C. Ashok Kumar (H.O.D),
 CMR-EC, JNTU University, Hyderabad, India
 Email: sthackeray.st@gmail.com

Abstract:

To Develop Irrigation in farmland using recent day-to-day technology for Effectiveness in water saving and to minimize cost of water Irrigation. Main focus of this paper is to investigate the sensor network nodes to achieve system hardware & software design, middleware & application of Android mobile phone, will include a Variety of sensor based network to maximize the entire automated system & monitoring levels. The final analysis of the system will be based on monitored data from the farmland through the diploid network on the field in real time and to control the irrigation automation. Application results prove to be effective in implementing embedded control technology with complete intelligence to improve water use efficiency and reduce power consumption due to regulated flow of water as per plant requirements; field soil moisture content & temperature. User uses Android cell phone or wireless PDA to maintain constant supervision on the automated system that is used for water irrigation.

Block diagram:

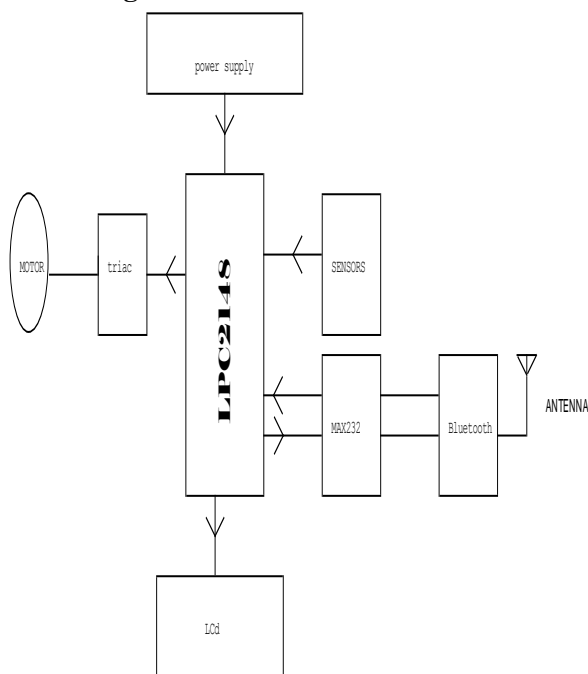

Fig 1: Block Diagram.

Keywords:

- Lpc2148
- Max232
- Regulated power supply
- Triac
- Irrigation Motor

- Sensors
- Bluetooth

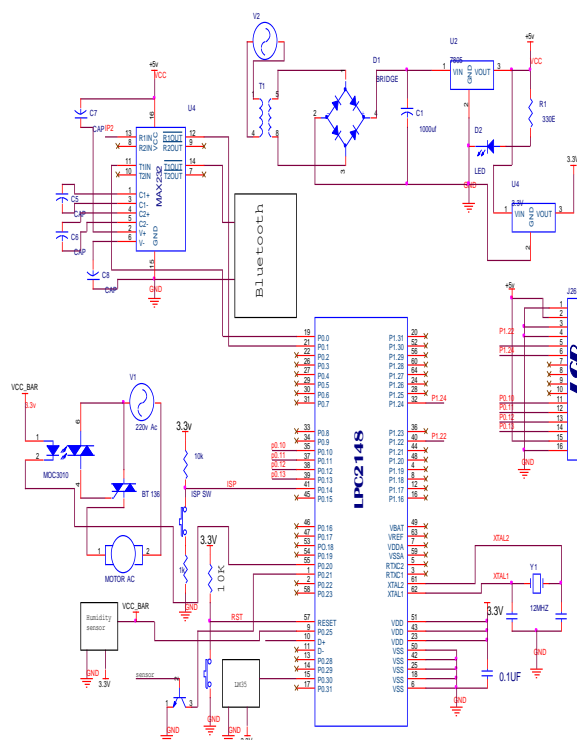

Fig 2: Schematic Diagram.

I. Introduction:

There are various parameters that can control the automatic irrigation system for instance soil

moisture measurement, estimates, leaf water potential canopy temperature etc. And this project includes the device working on the basic principle of soil moisture measurement using soil moisture measurement sensor. This sensor works on the basis of the flow of current between its electrodes measuring the resistance between them. Thus, simply when the soil is dry the resistance is maximum resulting in no current flow and sends a pulse to the centralized system about the moisture content in the soil & vice-versa to turn ON/OFF the motor pump. Electromagnetic Solenoid valves placed on the fields decide the distribution of water in only required regions as per the needs to reduce water wastage reduce power consumption. The processor Discards excess water flow through the specific valves to the region where the soil moisture content is above the required level. In the above process the pump activating resistance point can be set high for a plant that needs less water & vice-versa. Although some research is needed to find out the corresponding equivalent resistance value of the soil moisture level needed by the various variety of crops/plants as shown in **figure 3**.

II. Existing Research Results

In the internet of things related techniques, domestic currently in wireless sensor network software made corresponding breakthrough on the operating system based on foreign to develop their own middleware software. Such as the Nanjing University of Posts and Telecommunications research center for development of wireless sensor networks based on mobile agent middleware platform for wireless sensor networks, shenglian technology development of wireless sensor network development kits. Domestic research institutions in the theoretical research, such as network protocols for wireless sensor networks, algorithms, architecture, etc., put forward a number of innovative ideas and theories. In this field, Nanjing University of posts and telecommunications, Tsinghua University, Beijing University of Posts and so made some relevant theoretical research results. In other countries, many American universities in the wireless sensor network have carried out a lot of work. Such as the University of California, Los Angeles, CENS (Center for Embedded Networked Sensing) Laboratory, WINS (Wireless Integrated Network Sensors) Laboratory and IRL (Internet Research Lab) and so on. This paper reference some enterprise's actual production processes, from home and abroad to the traceability system related research, through research based on internet of things water-saving irrigation system scheme, the original traceability system based on Web water-

saving irrigation processing scheme must be improved

III. Working:

This project contains totally three sensors viz. moisture sensor, humidity sensor and temperature sensor. The moisture is a conductive sensor it works on the basis of conductivity. We will place this sensor in the soil if there is no water in the soil the conduction takes place between conductive sensor terminals, in this condition the sensor gives low output like if there is water in soil the sensor output gives high out. Here we have connected the output of sensor to the p0.20 pin of microcontroller Depending upon the water the microcontroller will switch the motor with p0.21 pin. Here we are also monitoring temperature and humidity using AD0.3 and AD0.4. The project contains Bluetooth, here we are using Bluetooth module to send the motor status and temperature, humidity values to the android phone and means we can check all data in real time frame on cell phone also; the system advantages are given below:

Automatic irrigation control system has the following advantages:

1. Will give full play to the role of the existing water-saving devices, optimal operation and improve efficiency.
2. Through the application of automatic control technology, more water and energy conservation, reduce irrigation Costs and improve the quality of irrigation.
3. Will irrigate more scientific, to facilitate and improve the management level. Control the development and Promotion of water-saving irrigation technology is the need for agricultural modernization.

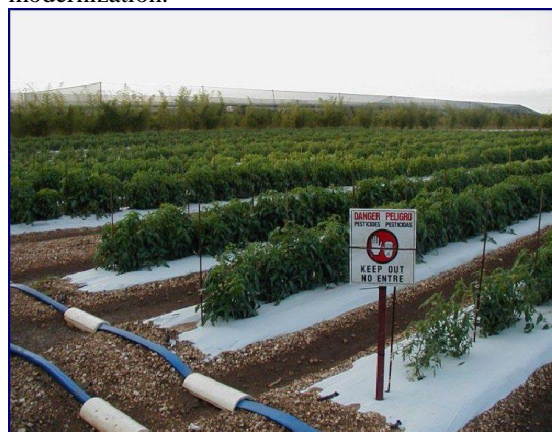

Fig 3: Water Distribution being carried out on field

IV. About moisture sensor

This moisture sensor can read the amount of moisture present in the soil surrounding it. It's a low tech sensor, but ideal for monitoring an urban garden, or your pet plant's water level. This is a must have tool for a connected garden! This sensor uses the two probes to pass current through the soil, and then it reads that resistance to get the moisture level. More water makes the soil conduct electricity more easily (less resistance), while dry soil conducts Electricity poorly (more resistance). It will be helpful to remind you to water your indoor plants or to monitor the soil moisture in your garden. The model of moisture sensor has shown in figure.2



Fig 4: Moisture sensor

HC Serial Bluetooth Description:

This is class-2 Bluetooth module with Serial Port Profile, which can configure as either Master or slave. A Drop-in replacement for wired serial connections and transparent usage. We can use it simply for a serial port replacement to Establish connection between HC-05 Specification

HC-05 Specification

- Bluetooth protocol: Bluetooth Specification v2.0+EDR
- Frequency: 2.4GHz ISM band
- Modulation: GFSK(Gaussian Frequency Shift Keying)
- Emission power: =4dBm, Class 2
- Sensitivity: =-84dBm at 0.1% BER
- Speed: Asynchronous: 2.1Mbps(Max) / 160 kbps, Synchronous: 1Mbps/1Mbps
- Security: Authentication and encryption
- Profiles: Bluetooth serial port
- Power supply: +3.3VDC 50mA
- Working temperature: -20 ~ +75Centigrade
- Dimension: 26.9mm x 13mm x 2.2 mm

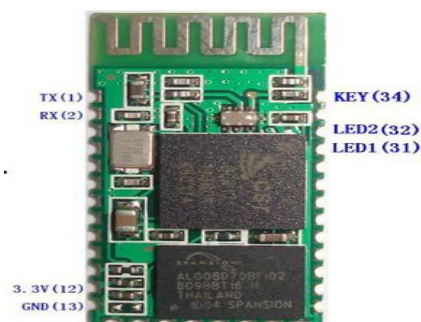

Fig 5: Bluetooth Module

Application

- Computer and peripheral devices
- Industrial control



Fig 6: Snapshot of the Project

V. Result

The prototype can show successfully required output to achieve primary target for demonstration. While working on this project failing numerous times taught new lessons to reduce errors and will be useful for professional times. The most important factor is the microcontroller programming learnt during this project along with many new things.

References

- [1.] Dukes, M.D.; Simonne, E.H.; Davis, W.E.; Studstill, D.W.;Hochmuth, R. 2003. Effect of sensor-based high frequency irrigation on bell pepper yield and water use. Proceedings of 2nd International Conference on Irrigation and Drainage,May 12-15.
- [2.] Dukes, M.D.; Scholberg, J.M. 2005. Soil moisture controlled subsurface drip irrigation on sandy soils. Applied Engineering in Agriculture 21(1):89-101.
- [3.] Irmak, S.; Haman, D.Z. 2001. Performance of the Watermark granular matrix sensor in

- sandy soils. *Applied Engineering in Agriculture* 17(6):787-795.
- [4.] Meron, M.; Hallel, R.; Peres, M.; Bravdo, B.; Wallach, R.;Gieling, T. 2001.
- [5.] Muñoz-Carpena, R., Li, Y.; Olczyk, T. 2002. Alternatives for Low Cost Soil Moisture Monitoring Devices for Vegetable Production in the South Miami-Dade County Agricultural Area. Fact Sheet ABE 333 of the Dept. of Agr. And Bio .Engineering, University of Florida. <http://edis.ifas.ufl.edu/AE230>. Last accessed 21 April 2005
- [6.] Muñoz-Carpena, R. 2004. Field Devices for Monitoring Soil Water Content. Extension Bul. 343 of the Dept. of Agr.and Bio. Engineering, University of Florida. <http://edis.ifas.ufl.edu/AE266>. Last accessed 21 April 2005.
- [7.] Nogueira, L.C.; Dukes, M.D.; Haman, D.Z.; Scholberg, J.M.;Cornejo, C. 2003. Data acquisition and irrigation controller based on CR10X data logger and TDR sensor. *Proceedings Soil and Crop Science Society of Florida* 2002, 62:38-46.
- [8.] Phene, C.J.; Howell, T. A. 1984. Soil sensor control of high frequency irrigation systems. *Transactions ASAE* 27 (2):392-396.
- [9.] Shock, C.C.; Feibert, E.B.G.; Saunders, L.D.; Eldredge, E.P.2002. Automation of subsurface drip irrigation for crop research. In, *Proceedings of the World Congress of Computers in Agriculture and Natural Resources*, F.S. Zazueta and J. Xin eds. 13-15 March 2002, Iguacu Falls, Brazil.,809-816.
- [10.] Smajstrla, A.G.; Koo, R.C. 1986. Use of tensiometers for scheduling of citrus irrigation. *Proceedings of the Florida State Horticultural Society* 99:51-56.
- [11.] Smajstrla, A.G.; Locascio, S.J. 1996. Tensiometer-controlled drip irrigation scheduling of tomato. *Applied Engineering in Agriculture* 12(3):315-319.